

Modular C-frame programme

Series CEJ

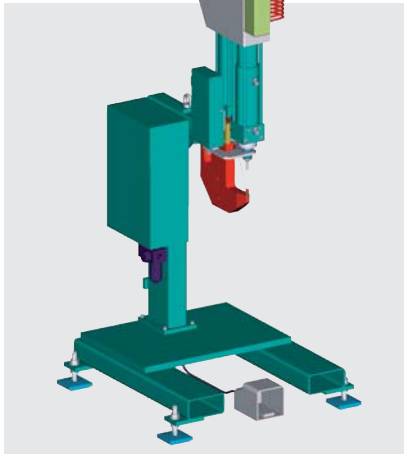

Picture shows:
Flexible modular system provides a universal upright press.

Example: bracket CEJ

consisting of:

- CEJ bracket
- Drive..... TOX®-Powerpackage RZK/RZH/RZS/EPMR
- CER..... support for holding the CEJ
- CLX safety device (see page 16)

Additional Accessories

- STE safety control
- CZP holding fixture
- CSR..... punch stripper
- ZKF coupling flange
- ZL target feature with light spot (see page 16)

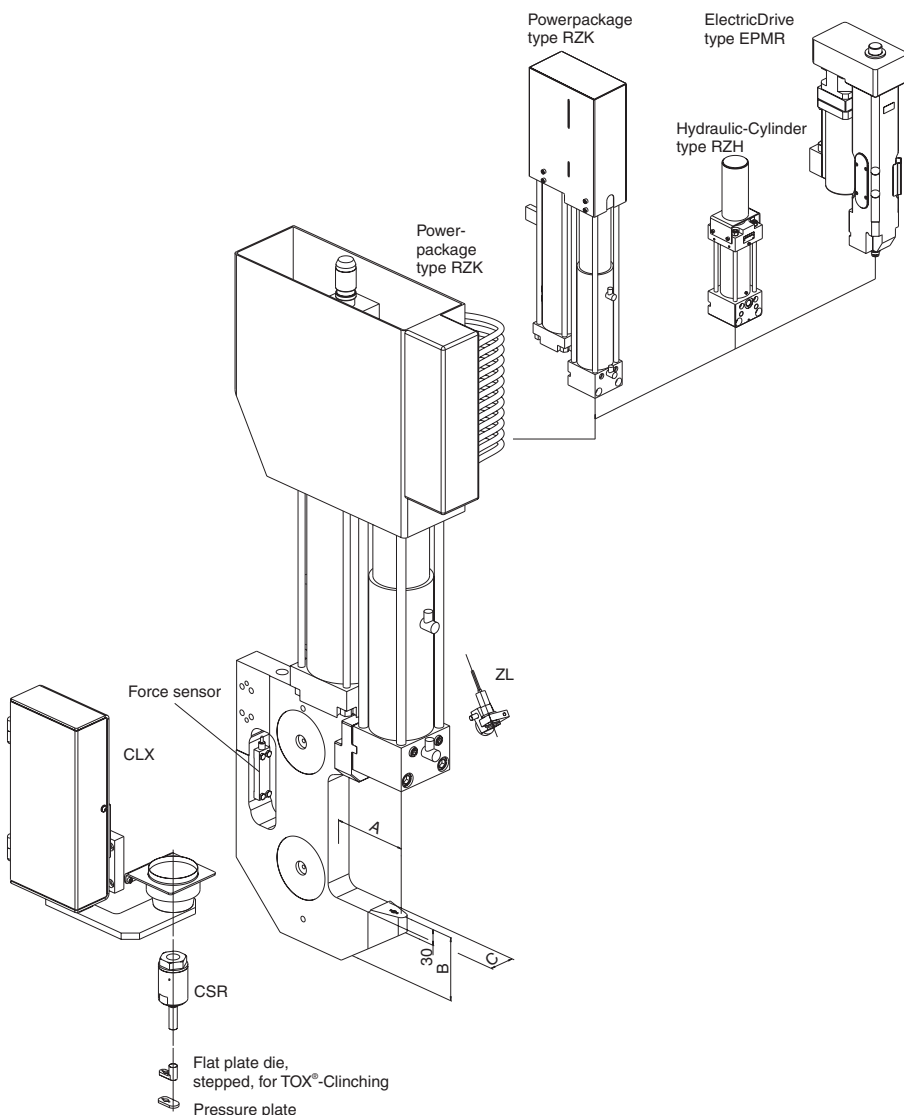

Press CEJ:

The C-frames can be designed according to the requirements. The press force, tool geometry or tool adapters can be changed as required.

Support CER:

Of solid welded construction with large open space so that the C-frame CEJ can be mounted in such a way that an optimal handling of the component by the operator is possible.

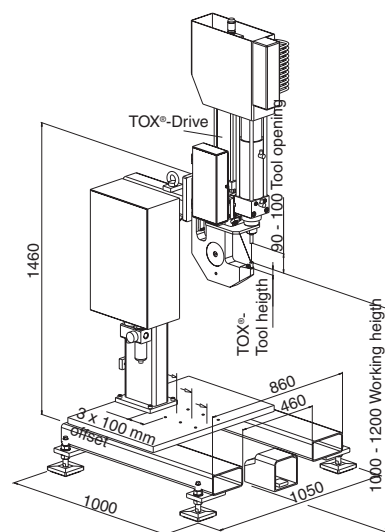

CEJ 50

order number	max. press force kN	stroke	A	B	C
CEJ 50.100	50	100	100	75	40
CEJ 50.150	50	100	150	115	40
CEJ 50.200	50	100	200	145	40

All dimensions in mm.

CEJ 80

order number	max. press force kN	stroke	A	B	C
CEJ 80.100	80	100	100	85	50
CEJ 80.150	80	100	150	120	50
CEJ 80.200	80	100	200	165	50

All dimensions in mm.